

SPRINT™ HOLDFAST

INSTALLATION ON A "PULL" DOOR.

Fix the L-bracket
on the header.

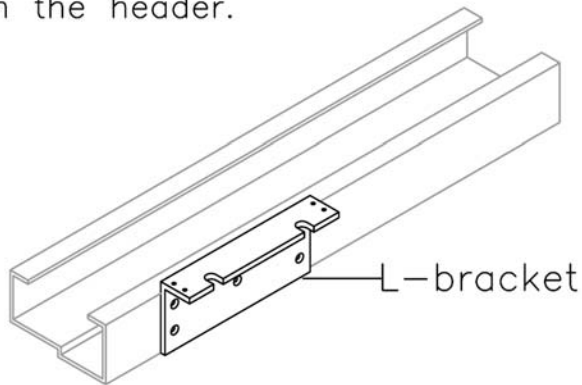

Step 1.

Remove mounting
plate from maglock.

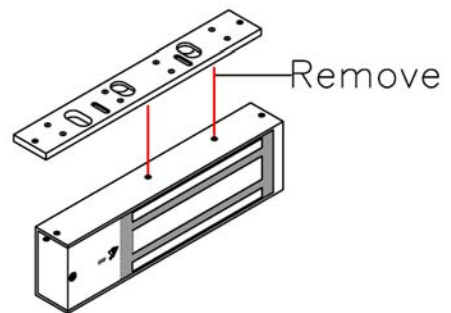

Step 2.

Fasten to L-bracket
with mounting screws.

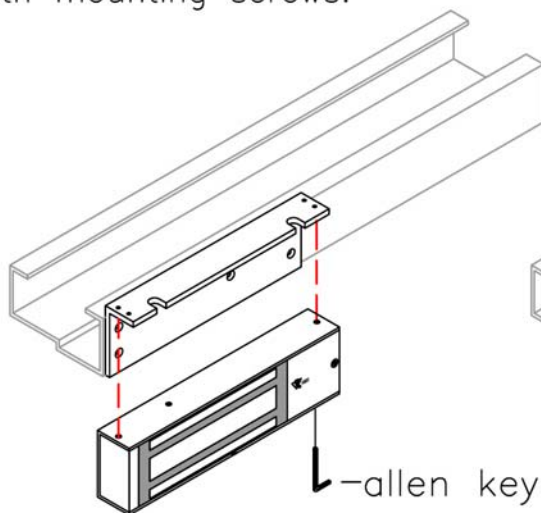

Step 3.

Insert anti-tamper
pins.

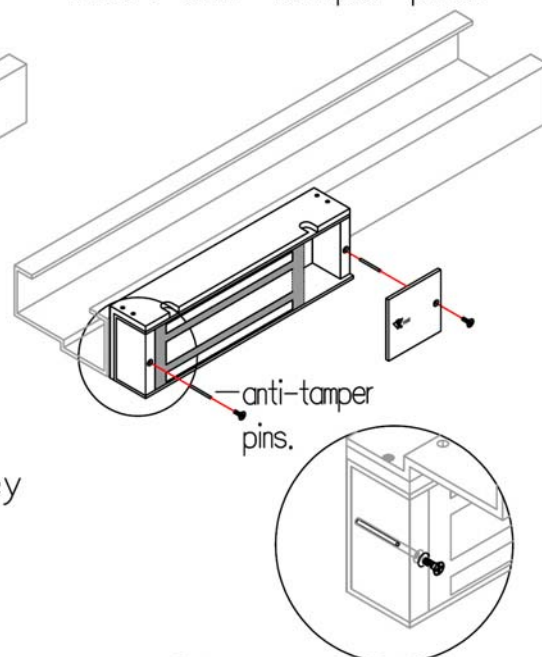

Step 4.

SPRINT™ HOLDFAST

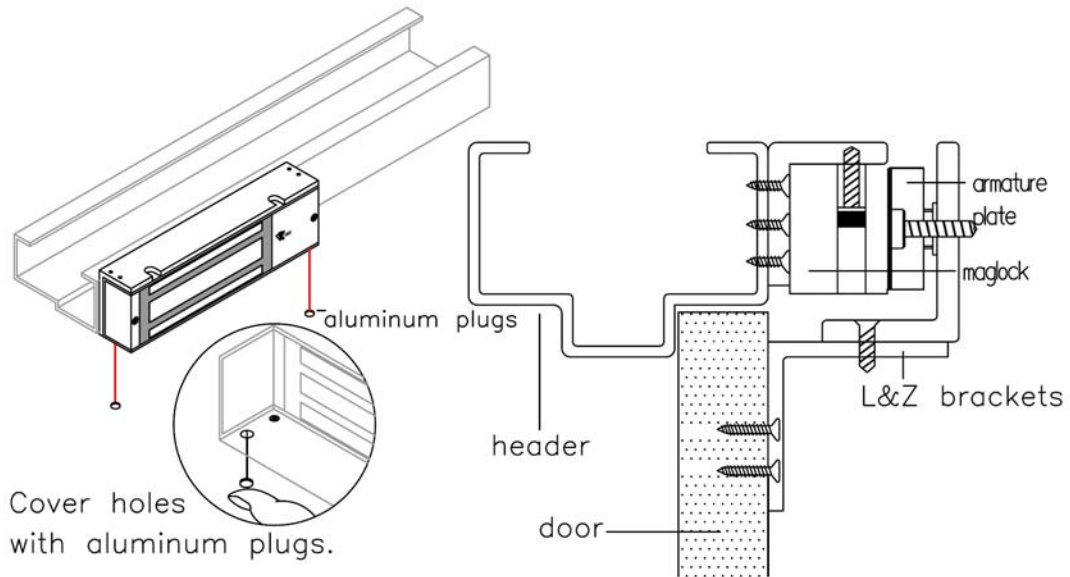

Step 5.

INSTALLATION OF ARMATURE PLATE ON Z-BRACKET.

